



### ARTICLE CODE

S10 - 12 A R - B

## S10&S10C Series

Nil:Standard  
 B:Plastic Bracket Cover  
 Nil:Standard  
 R:With resistance  
 D:With diode  
 Nil:1C  
 A:1A  
 B:1B  
 U:1U  
 Coil voltage  
 12,24 VDC  
 Model Name  
 S10:Standard type  
 S10C:Mini type



#### Main Features:

- Small size and light weight.
- Heavy contact load (40A).
- Contact arrangement Form A and Cavailable.
- Suitable for automobile and lamp accessories application.
- PC board mounting and direct inser mounting available.

### COIL RATING(at 20°C)

Type	Rated Voltage (VDC)	Coil Resistance (Ω)(±10%)	Rated Power (W)	Nominal Current (mA)(±10%)	Pull In Voltage (VDC)	Drop Out Voltage (VDC)
S10	12V	90Ω	1.6W	133.3mA	7.8V	1.2V
	24V	360Ω		66.7mA	17.0V	2.4V
S10C	12V	103Ω	1.4W	117mA	7.8V	1.2V
	24V	320Ω	1.8W	75mA	17.0V	2.4V

### PERFORMANCE(at initial value )

Item	Type	S10	S10C
Contact Resistance		50mΩ Max.(Initial Value)	
Operate Time		7msec Max.	
Release Time		5msec Max.	
Dielectric Strength between Coil & Contact between Contact		750VAC(1min) 500VAC(1min)	1000VAC(1min) 500VAC(1min)
Insulation Resistance		50MΩ Min.(DC500V)	
Operating Ambient Temperature		-40°C~+125°C	-40°C ~+75°C
Humidity		35 to 85% RH	
Vibration Resistance		10G(10~55Hz)(Dual Amplitude:2mm)	
Shock Resistance		10G	
Life Expectancy Mechanically Electrically		10,000,000 ops.Min.(1800 ops./h) 100,000 ops.Min.(1200 ops./h)	
Weight		48g(approx.)	40g(approx.)

### CONTACT RATING

Item	Type	S10	S10C
Rated Carrying Current		40A/14VDC	
Max. Allowable Current		50A	
Max. Allowable Voltage		32V	
Max. Current(continual)		40A	
Contact Material		Ag alloy	

### OUTLINE DIMENSION, WIRING DIAGRAM & PC BOARD LAYOUT

Unit: mm

S10

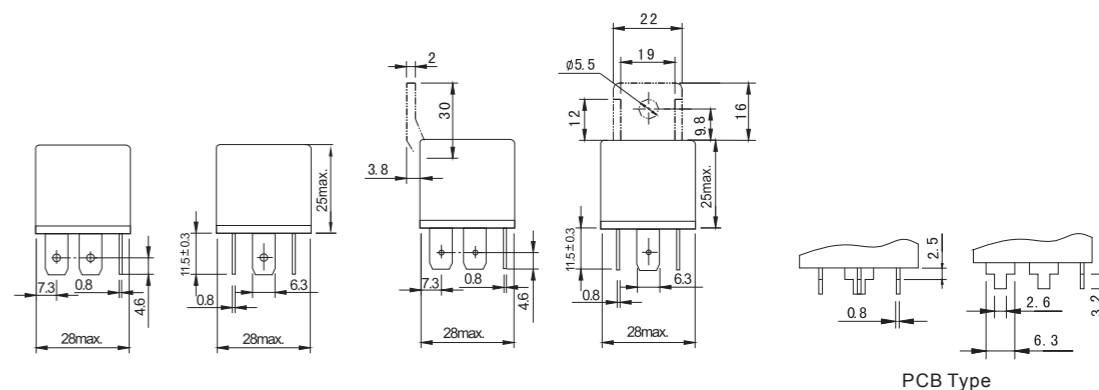

PCB Type

Note: Terminals as shown above are also available.

S10C

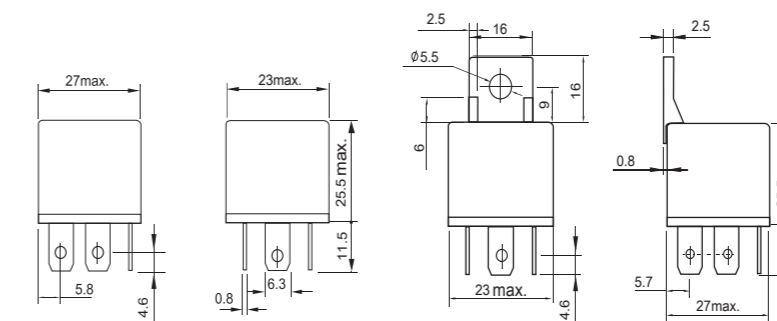

Dimensions

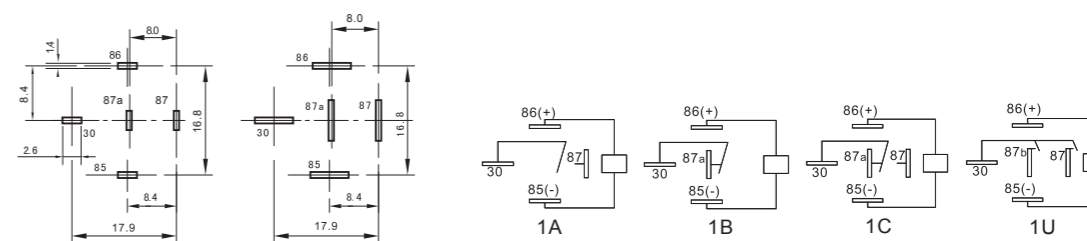

PCB

Plug in type

Wiring diagram (Bottom view)

Mounting (Bottom view)

- Remark: 1) In case of no tolerance shown in outline dimension: outline dimension ≤1mm, tolerance should be ±0.2mm; outline dimension >1mm and ≤5mm, tolerance should be ±0.3mm; outline dimension >5mm, tolerance should be ±0.4mm.  
 2) The tolerance without indicating for PCB layout is always ±0.1mm.  
 3) The width of the gridding is 2.54mm.