



ARTICLE CODE

S21 - 12 A

S21 Series



Nil:1C
A:1A
Coil Voltage
5,6,9,12,18,24,48 VDC

Model Name:S21

Main Features:

- 1 form A(SPST) contact
- Heavy current up to 16amps
- Nominal power 200 mw
- High sensitivity in small package

COIL RATING(at 20°C)

Nominal Voltage (VDC)	Coil Resistance (Ω)(±10%)	Power Consumption(W)	Nominal Current (mA)(±10%)	Pull In Voltage (VDC)	Drop Out Voltage (VDC)	Max. Allowable Voltage (VDC)
5V	125Ω	0.2W	40.0mA	75% MAX	5% MIX	130%
6V	180Ω		33.3mA			
9V	405Ω		22.2mA			
12V	720Ω		16.7mA			
18V	1620Ω		11.1mA			
24V	2880Ω		8.3mA			
48V	11520Ω		4.2mA			

PERFORMANCE(at initial value)

Item	Type	16A
Contact Resistance		50mΩ Max.(Initial Value)
Operate Time		10msec Max.
Release Time		10msec Max.
Dielectric Strength between Coil & Contact between Contact		1500VAC(1min) 7500VAC(1min)
Insulation Resistance		100MΩ Min.(DC500V)
Operating Ambient Temperature		-40°C ~+85°C
Humidity		35 to 85% RH
Vibration Resistance		10G(10~55Hz) (Dual amplitude:1.5mm)
Shock Resistance		10G
Life Expectancy Mechanically Electrically		10,000,000 ops.Min.(1800 ops./h) 100,000 ops.Min.(1200 ops./h)
Weight		10g(approx.)

CONTACT RATING

Item	Type	16A
Rated Carrying Current		16A/250VAC 16A/30VDC
Max. Allowable Current		16A
Max. Allowable Voltage		380VAC 110VDC
Max. Current(Continual)		16A
Contact Material		Ag alloy

OUTLINE DIMENSION, WIRING DIAGRAM & PC BOARD LAYOUT

Unit: mm

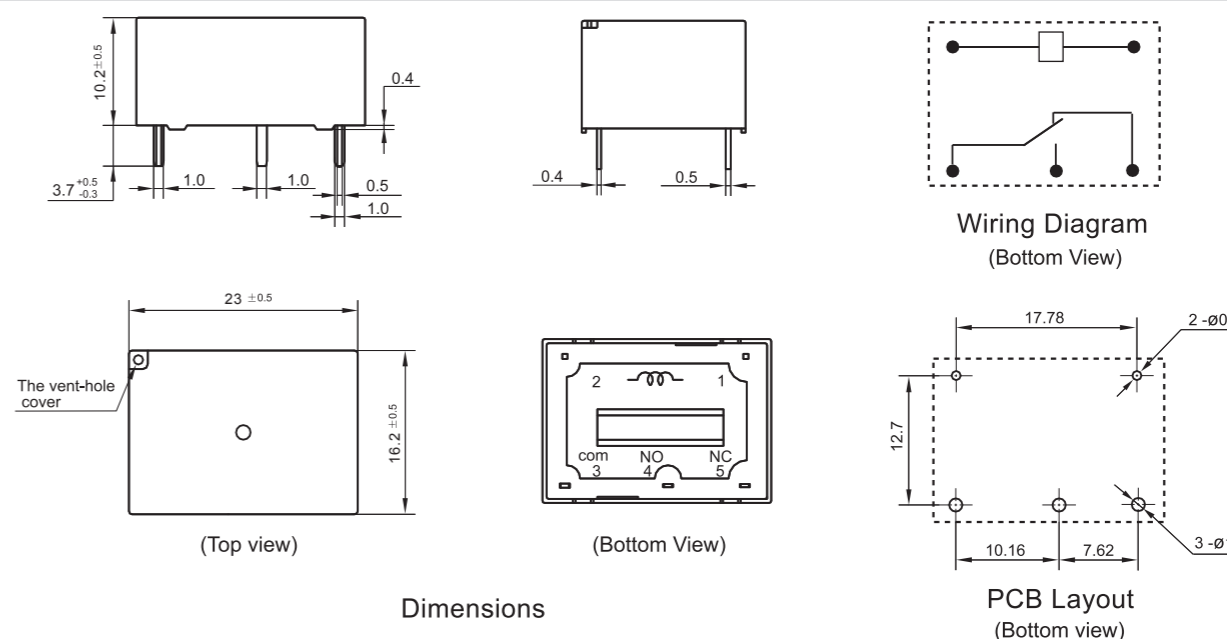

Dimensions

Remark: 1) In case of no tolerance shown in outline dimension: outline dimension ≤1mm, tolerance should be ±0.2mm; outline dimension >1mm and ≤5mm, tolerance should be ±0.3mm; outline dimension >5mm, tolerance should be ±0.4mm.

CHARACTERISTIC CURVES

